

The single fixture light cart is designed to provide portable lighting solutions for applications ranging from inspection to laboratory and general industrial task lighting. Light fixture options allow you to customize your cart to fit your work application requirements. SOME ASSEMBLY REQUIRED.

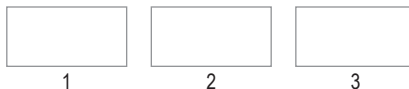

1 SERIES	2 FIXTURE	3 VOLTAGE
4346: Light Cart	INS: Inspection (Tempered, Striped Glass) I: Open industrial (UL 1598)	120: 120V Standard 277: 277V Optional

FIXTURE LISTINGS

ETL listed. U.S. and Canada
INS: Non-Hazardous
I: UL 1598 ONLY

ELECTRICAL

Available in 32 watt with T8 lamps
Voltage: 120 Volts or 277 Volts

OPTIONS

Cart Options

Shelf trays: 20 1/2" W x 8" D x 3" H (Qty 2) (P/N 7638)

Fixture Options

INS: Inspection with tempered, striped lens (lamps included)
I: Task/Open industrial with polycarbonate lens (lamps included)

Replacement Parts

Polycarbonate replacement Lens (P/N 7756)
F32-T-8 Lamp, 5000K - (Recommended)

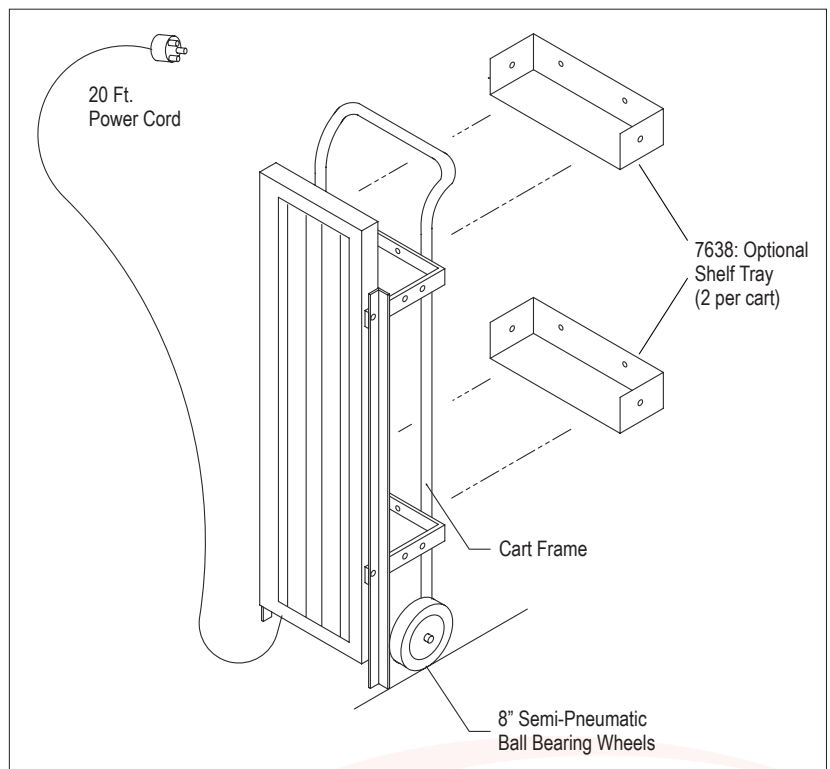

CARTS

PORTABLE LIGHTING - MULTI FIXTURE

Industrial • Task Lighting



The 4 Ft. 2 and 3 fixture light carts are designed to provide portable lighting solutions for applications ranging from inspection to laboratory and general industrial task lighting. A 4 Ft. single fixture horizontal mount cart is also available for all fixture types. Fixtures are attached with swivel mounting brackets allowing for directional aiming of the light (Hazardous location fixtures are stationary mounted). ASSEMBLY REQUIRED.

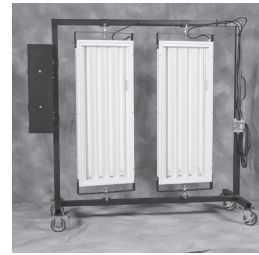

Vertical Mount



Horizontal Mount 2 Fixture Only

Shown with optional tool tray

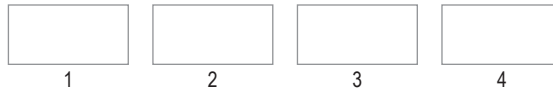

1 SERIES	2 WHEELS	3 FIXTURE	4 VOLTAGE
3668: 2 Fix. Cart 3669: 3 Fix. Vertical Cart 4520: 1-4 Ft. Horizontal Cart	P: 10" Tires Pneumatic (Std)	INS: Inspection Tempered, Striped Glass I: Open Industrial (UL 1598)	120: 120V Standard 277: 277V Optional

FIXTURE LISTINGS

ETL listed. U.S. and Canada
 INS: Inspection
 I: UL 1598 ONLY

ELECTRICAL

Voltage: 120 Volts or 277 Volts
 Amperage: 15 amps standard

OPTIONS

Cart Options

Vertical or horizontal fixture mount (1 or 2 fixture carts only)
 Outlet box with 1 duplex outlet available for 120 Volts carts P/N 7641
 Tool tray with adjustable shelves P/N 7640
 NEMA rated power cord plug, other than specified, can be provided.

Fixture Options

INS: Inspection with tempered, striped lens (lamps included)
 (vertical mount recommended)
 I: Task/open industrial (lamps included)

Replacement Parts

Polycarbonate lens
 F32-T-8 lamp, 5000K - (recommended)



Standard 10" Pneumatic Tires

25 Ft. Main Power Cord

7641: Optional Outlet Box

7640: Optional Tool Tray With Adjustable Shelves

Standard 10" Pneumatic Tires

Standard 10" Non-Swivel Pneumatic Tires

7640 and 7641 are for Multi Fixture Carts ONLY.

4520: 1-4Ft. Horizontal Fixture

3 Fixture Cart Vertical Mount ONLY